

# Mobile Phone Battery Charger with Emergency Light

A very easy circuit of “variable power supply and charger” is being explained here. It is not very much useful in the time of power cut but also used as main power supply. At your workbench you can use this circuit to check or testing of your electronic projects. Mobile phone batteries can be charged with the help of these circuits. This circuit can work as an emergency light.

## Mobile Phone Battery Charger Circuit Diagram:

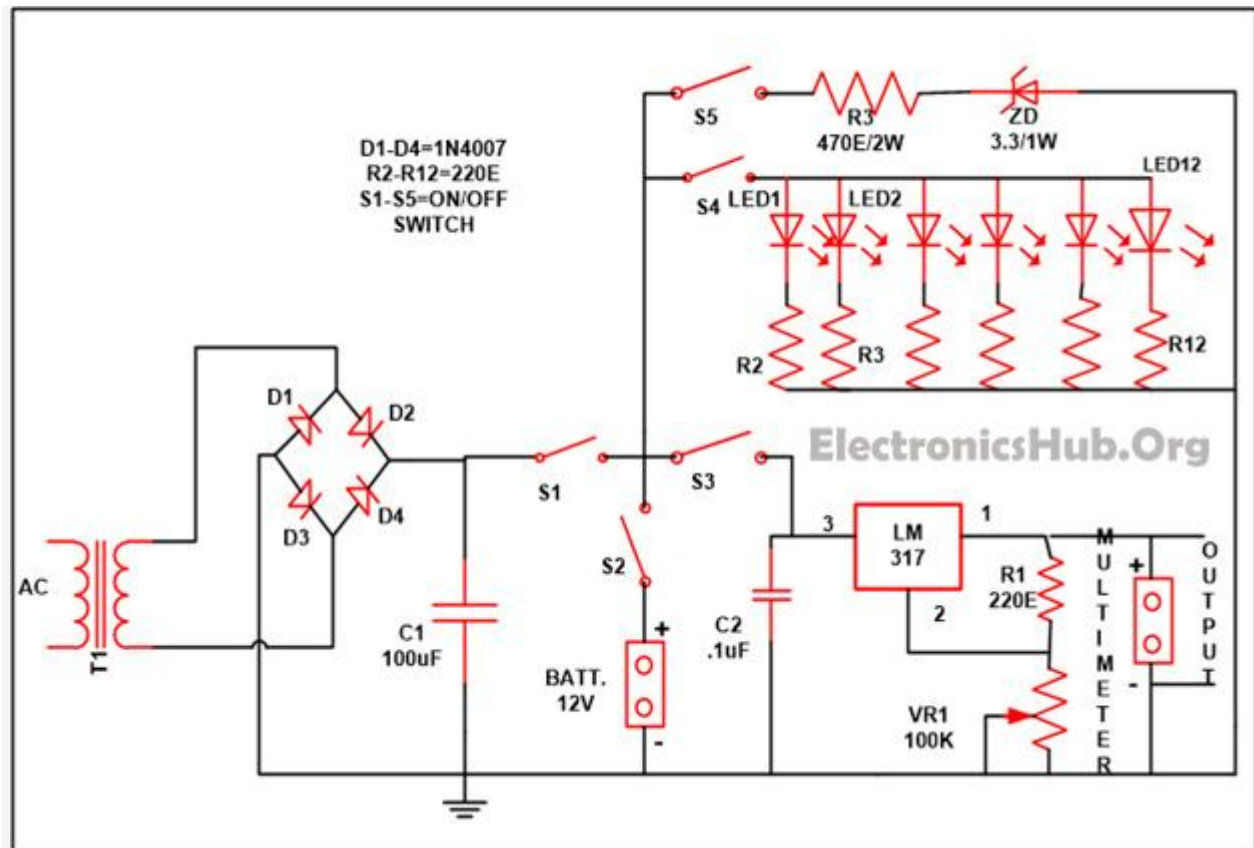

Mobile Phone Battery Charger Circuit – [ElectronicsHub.Org](http://ElectronicsHub.Org)

## Working of Mobile Phone Battery Charger Circuit:

As per your need you can take the output from the circuit by just flipping the different number of switches (from S3, S4 and S5) in the circuit. If you require the variable power supply as your output than set switch S3 into “on” state. LM317 is used in the circuit which is a [variable voltage regulator](#) to supply variable power. The LM317 is basically positive voltage regulator has three terminals. 1.2 V to 37V is the range of the output voltage that is provided by the LM317. Different range of voltage can be achieved by just adjusting the variable resistor that is provided in the circuit and with the help of multimeter output can be seen and the voltage which is desirable can set. The power supply range can alter from 1.5V to 12V.

With the help of flipping the S5 switch which is provided in the circuit Li-ions battery can be charged, which are generally used in the mobile phones with the assist of your mobile connectors. While the charging current in the circuit is being

controlled with the help of resistor R13. Turn over to switch S5 if you want to use the emergency light. Reflectors can be used in the circuit if you wish to enlarge the intensity of light.

S1 and S2 are the two switches that are given in the circuit so that you can power your circuit either directly with the AC supply or else you can take help of any battery. If you want to use an AC supply than flip to switch S1 while if you want to have supplied from the battery than flip to switch S2. In the place of AC power supply solar panels can be used and for storing the charge you can take rechargeable batteries, this will not merely save electric bill but also assist you a lot in the state of power failure.

#### **Circuit Components:**

- LM317 – 1
- Resistor
- R1 (220E) – 1
- R2-R12 (220E) – 11
- R13 (470E)
- VR1 (100K) – 1
- C1 (100uF) – 1
- C2 (. 1uF) – 1
- D1-D4 (1N4007) – 4
- S1-S5 (on/off switch) – 5
- LED1-LED12 – 12
- Transformer – 1
- Battery – 1
- Zener diode (3.3) – 1

#### **Components Description:**

1. **LM317:** It is a variable voltage supplier. It is a device with three terminals. It works on voltage range of 1.25 V to 37 V at a current of 1.5 amps.
2. **Resistor-** The flow of current in any of the circuit is being controlled by the resistor. It is basically a passive device. There are two types of resistor available i.e
  1. **Fixed Resistor** – whose value of resistance is fixed
  2. **Variable Resistor** – whose value of resistance can vary
3. **Capacitor-** It is used to store the electrical charges . It is also a passive device and are available in the market in two types i.e.
  1. **Polarized Capacitor** – Capacitors with polarity i.e. have + and – terminal eg electrolytic capacitor
  2. **Non-Polarized Capacitor** – Capacitor without any polarity e.g. ceramic and paper capacitor.
4. **Diode** - It is mainly used to allow the single directional flow of current. It is a passive device with two terminals.
5. **Switches** -Literal sense of a switch is “transform of state”. In an electrical logic, ON and OFF are the two conditions and switch assist to alter the condition of an electrical machine from ON to OFF or reverse. Firmly talking, it doesn't turn on or off the machine; it merely creates or break the contact.
6. **LED (Light emitting diode)** – It is a semiconductor device that produces a diverse source of beam at its output. When they are electrically biased in the forward state of p-n junction it emits a narrow spectrum of light. LED are found in the market very easily in a variety of colors via red, yellow, green and many more like white, orange etc.

7. **Transformer** -A transformer is a device which is used for transforming current from one circuit to another. During the transformation process, characteristic of AC signal changes. For example a low voltage AC may be changed to a high voltage AC and vice versa. The working of the transformer is based on the magnetic field to build around the conductor when current flows through it. This principle is called as electromagnetic mutual induction. Transformers are made up of two coils of wire wrapped around a core.
8. **Battery** - Battery is mainly a group of one or more than one electrochemical cell and in that chemical energy that is already stored is turned into electrical energy. From the age of Volta the principles of operation have not been altered. Every cell in the battery is made up of two halves of cells which are linked in series via an electrolytic solution. While 1/3 of the cell is made up of two houses named as the anode and cathode positive ions of the anode roam from the electrolyte to the cathode.
9. **Zener Diode** - This diode work in the reverse bias state and start conducting when the voltage achieves the break point. If you want to get stable voltage then all you need is to couple a resistor across it so that current flow can control.

Source: <http://www.electronicshub.org/mobile-phone-battery-charger-with-emergency-light/>